

### GAMMA-X: N-type Coaxial HPGe Detectors for High-Performance Gamma Spectroscopy in the Energy Range of ~3 keV and Upward

The GAMMA-X detector is a coaxial Germanium (Ge) detector with an ultra-thin entrance window. While most coaxial detectors have entrance windows from 500- to 1000- $\mu\text{m}$  thick, the entrance window of the GAMMA-X detector is a 0.3- $\mu\text{m}$ -thick, ion-implanted contact, extending the lower range of useful energies to around 3 keV. Ion implantation results in a totally stable contact which will not deteriorate with repeated cycling. Moreover, N-type HPGe detectors have been shown to be resistant to damage by fast neutrons.

All GAMMA-X Series detectors feature:

- Efficiencies to 100%, higher on request.
- Spectroscopy from 3 keV to 10 MeV.
- ULTRA thin boron ion implanted radiation window, ideal for Compton Suppression systems.
- Neutron damage resistant; user self-repair neutron damage option.
- Excellent energy resolution and peak symmetry.
- SMART bias option.
- Harsh Environment (-HE) option.
- Be window supplied with protective cover; Al or carbon fiber window option available at no additional charge.
- Low-background carbon fiber endcap option.
- PLUS preamplifier option for ultra-high-rate applications.
- Huge configuration flexibility, PopTop, Streamline, and mechanically cooled options.

GAMMA-X Series detectors are manufactured from ORTEC- grown germanium crystals processed in our advanced manufacturing facility in Oak Ridge, TN. The detectors are fabricated from N-type germanium with an inner contact of diffused Li and an outer, ultra thin, contact of ion-implanted boron.

The wide energy range of application of the GAMMA-X detector is illustrated in Figure 1 which compares the relative efficiencies of a GAMMA-X, a GEM (P-type coaxial), and a GLP planar detector. The GAMMA-X detector, uniquely, demonstrates excellent efficiency at both high and low energies.

ORTEC offers GMX Series HPGe detectors with relative efficiencies from 10% to 100% and beyond.

ORTEC maintains a large stocklist of HPGe detectors. Some of these have "super specifications," that is, a warranted energy resolution better than the usual warranted specifications.

#### High- and Low-Energy Performance of the GAMMA-X Detector

The high-energy performance of a GAMMA-X detector is defined by its relative efficiency, resolution, and peak-to-Compton ratio at  $^{60}\text{Co}$ .

The low-energy performance of this detector is defined by its resolution at 5.9 keV, its active surface area, and the detector window thickness.

The thickness of the entrance contact of the GAMMA-X detector is described by the ratio of the areas of two peaks of a readily available source. The peaks chosen are those of the 88-keV gamma rays from the  $^{109}\text{Cd}$  and of the 22.16-keV Ag K x rays from the same source. The warranted window attenuation ratio is 20.

$$W_E = \frac{\text{peak area at 22.16 keV}}{\text{peak area at 88 keV}}$$

#### 22-keV Peak/88-keV Peak Area

This specification quantifies the thinness of the entrance window in GAMMA-X detectors. The natural ratio of gamma rays from the 22-keV and 88-keV lines of a  $^{109}\text{Cd}$  source is ~21:1. A GAMMA-X detector typically displays a ratio >20:1.

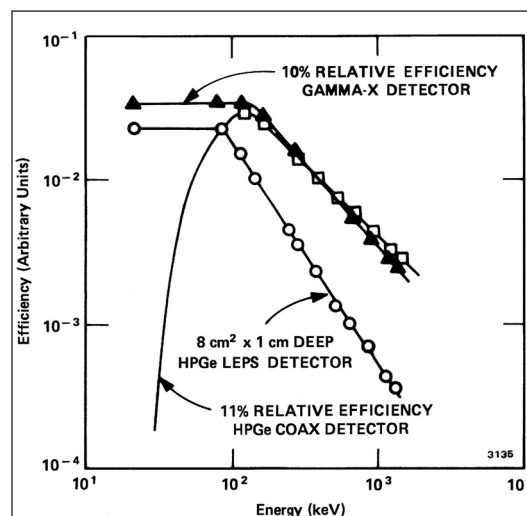

Fig. 1. Comparison of the Efficiency-Energy Curve of the LEPS, HPGe Coaxial, and GAMMA-X Detectors.

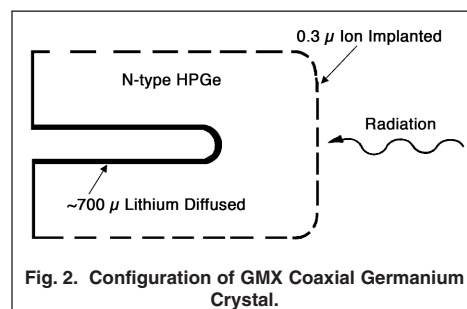

Fig. 2. Configuration of GMX Coaxial Germanium Crystal.

# GMX Series Coaxial HPGe Detector Product Configuration Guide

## Beryllium Window

GMX detectors in 70-mm (2.75-in.) or 76-mm (3-in.) diameter endcaps (10 to ~35%) are supplied with 51-mm (2-in.) diameter Be windows. GMX detectors in 83-mm (3.25-in.) diameter endcaps (~30 to 65%) are supplied with 64-mm (2.5-in.) diameter Be windows. These windows are 0.020-in. thick and have a transmission coefficient of ~95% at 5.9-keV. Detectors in 95-mm (3.75-in.) diameter endcaps (~60 to 100%) receive a 84-mm (3.3-in.) diameter Be window that is 0.030-in. thick.

## High-Voltage Shutdown and High-Rate Indicator

GAMMA-X detectors have high-voltage shutdown and high-rate indicator protection features. If the LN<sub>2</sub> supply is exhausted and the detector begins to warm while high-voltage bias is applied (when using the Model 659 Bias Supply), the high voltage automatically shuts off, thus protecting the FET from damage.

This is accomplished with a temperature sensor (located on the mount behind the detector) that shuts down the high voltage before the molecular sieve can outgas and cause a dangerous high-voltage arc. Using the high-leakage current of a warming detector to shut down the high voltage can result in FET and detector damage.

## Neutron Damage Resistance

In the GAMMA-X detector, electron collection is the dominant process. Fast neutrons generate hole-trapping centers; that is, negatively charged defects that trap holes but not electrons.

Therefore, the GAMMA-X detector, in which the hole collection process is of secondary importance, is basically less sensitive to radiation damage than coaxial Ge devices in which the hole collection process is of primary importance. These theoretical considerations have been experimentally confirmed.<sup>1</sup>

Figure 3, a plot of the 1.33-MeV FWHM resolution as a function of fast neutron fluence for both a GAMMA-X and a GEM detector of the same efficiency, shows that the GAMMA-X detector is far more resistant to fast neutron radiation damage.<sup>1</sup> The detector temperature affects its radiation damage resistance to fast neutrons.

It should be noted that **once severe radiation damage has occurred**, the “longest mileage” is obtained by avoiding cycling the detector to room temperature.<sup>2</sup> This is true for either p- or n-type Ge detectors. However, for slightly damaged GAMMA-X detectors (~0.1 keV degradation), cycling, or even leaving the detector warm for an extended period, will have no unfavorable effect.<sup>3</sup>

GAMMA-X detectors should be maintained at a temperature as close to 77 K as possible to minimize the extent of radiation damage. Therefore a streamline cryostat, with one less thermal connection, is a better choice than a PopTop for this purpose.

## Customer-Neutron-Damage-Repairable Detectors

Repair of neutron-damaged GAMMA-X detectors can be performed at any of our worldwide repair facilities, or by you in your own laboratory. Contact us for information about our Customer-Neutron-Damage-Repairable GAMMA-X detectors.

## The Following Specifications are Provided for each GMX Detector

- Energy resolution at 1.33-MeV photons from <sup>60</sup>Co at optimum shaping time.
- Relative Photopeak efficiency for a <sup>60</sup>Co 1.33-MeV peak.
- Peak-to-Compton ratio for a <sup>60</sup>Co 1.33-MeV peak.
- Peak shape ratio for the full-width tenth-maximum to the full-width half-maximum for a <sup>60</sup>Co 1.33-MeV peak.
- Energy resolution at 5.9-keV photons from <sup>55</sup>Fe at optimum shaping time unless the window material prevents detection at this energy.

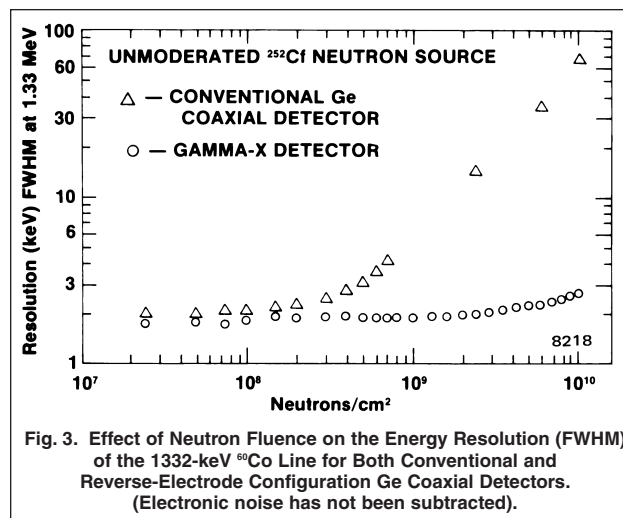

Fig. 3. Effect of Neutron Fluence on the Energy Resolution (FWHM) of the 1332-keV <sup>60</sup>Co Line for Both Conventional and Reverse-Electrode Configuration Ge Coaxial Detectors. (Electronic noise has not been subtracted).

<sup>1</sup>R.H. Pehl, N.W. Madden, J.H. Elliott, T.W. Raudorf, R.C. Trammell, and L.S. Darken, Jr., “Radiation Damage Resistance of Reverse Electrode Ge Coaxial Detectors,” *IEEE Trans. Nucl. Sci.* **NS-26**, N1, 321–23 (1979).

<sup>2</sup>H.W. Kraner, R.H. Pehl, and E.E. Haller, “Fast Neutron Radiation Damage of High-Purity Germanium Detectors,” *IEEE Trans. Nucl. Sci.* **NS-22**, N1, 149 (1975).

<sup>3</sup>T.W. Raudorf, R.C. Trammell, and Sanford Wagner, “Performance of Reverse Electrode HPGe Coaxial Detectors After Light Damage by Fast Neutrons,” *IEEE Trans. Nucl. Sci.* **NS-31**, N1, 253 (1984).

# GMX Series Coaxial HPGe Detector Product Configuration Guide

## Configuration Guidelines

### PopTop or Streamline (non-PopTop) Configuration

The essence of a PopTop detector system is that the HPGe detector element, preamplifier, and high voltage filter are housed in a detector “capsule” which is then attached to an appropriate cryostat (Figure 4.)

In so called Streamline systems, the detector capsule is NOT demountable. Detector capsule and cryostat share the same vacuum. In configuration terms, this requires a cryostat or cryostat/dewar selection with the cryostat having a matching diameter to the capsule endcap. A cryostat must always be ordered with a Streamline capsule, because they are integral.

The actual PopTop capsule has its own vacuum. It can be mounted on any of the available cryostats, cryostat/dewar combinations, or the X-COOLER II mechanical cooling system.

### Steps to Configure Your ORTEC HPGe Detector

#### 1) Configure the Detector Model

- Capsule type (PopTop or Streamline)
- Ge Crystal efficiency and specifications
- Endcap and window
- Mount
- Preamplifier
- High Voltage Filter
- Cable Package

Options are available for the detector model that can change specific materials used in the construction of the detector endcap, cup, and mount. Preamplifier options are also available.

#### 2) Configure the Cryostat/Dewar Model

- Vertical Dipstick style (separate Dewar)
- Horizontal Dipstick style (separate Dewar)
- Portable with all-position or multi-position cryostat/dewar models
- Downlooking designed to be oriented with the detector pointing down
- Sidelooking designed to be oriented with the detector horizontal at the bottom of the dewar
- “J” configurations designed with the detector attached near the bottom of the dewar and a right angle bend in the cryostat orienting the detector to look up.

A cryostat and dewar or other cooling device are required for operation.

If a PopTop detector has been selected, you can choose a PopTop style cryostat, cryostat/dewar combination or the X-COOLER II mechanical cooler.

If a Streamline detector has been selected, you must choose a cryostat or cryostat/dewar model for the detector to be mounted on and vacuum sealed. The cryostat or cryostat/dewar combination diameter must match the endcap diameter of the selected detector.

### Detector Options

#### Aluminum Window Option (-A)

An all aluminum endcap can be chosen if the energies of interest exceed 20 keV. See Table 1 for the transmission data for Al.

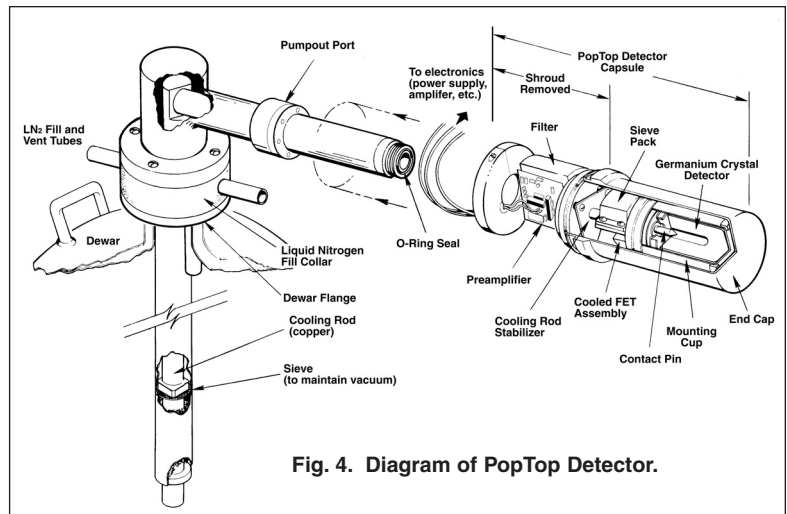

Fig. 4. Diagram of PopTop Detector.

Energy (keV)	% Transmitted
3	0
5	0
10	$8.5 \times 10^{-2}$
20	40
30	74
50	91
80	95
100	96
400	97
1000	98

<sup>1</sup>By convention, HPGe detectors are characterized by “relative efficiency”. Relative efficiency is defined as the efficiency of a point Co-60 source at 25 cm from the face of a standard 3-inch x 3-inch right circular cylinder NaI(Tl) detector. “IEEE Test Procedures for Germanium Detectors for Ionizing Radiatio,” ANSI/IEEE Standard 325-1986.

# GMX Series Coaxial HPGe Detector Product Configuration Guide

## Ultra-High Count-Rate Preamplifier Option (-PL)

The Ultra-High Count-Rate Preamplifier (transistor-reset preamplifier), which can handle input count rates up to 1,000,000 counts/s at 1 MeV, offers the added benefit of having no feedback resistor.

## Harsh Environment Option (-HE)

The Harsh Environment option is a rugged carbon fiber endcap with a sealed electronics housing featuring a replaceable desiccant pack which ensures that the electronics stay 100% dry and indicates when it needs to be replaced.

GMX series detectors in PopTop capsules of 76 mm diameter or larger can be supplied with this option.

## SMART-1 Option (-SMN)

The SMART-1 option monitors and reports on vital system functions, and can save authentication codes and report the code at a later time. It has the high voltage included, so none of the instruments require an external high-voltage power supply.

The SMART-1 is housed in a rugged ABS molded plastic enclosure and is permanently attached to the detector endcap via a molded-strain-relieved sealed cable. This eliminates the possibility that the detector will suffer severe damage from moisture leaking into high-voltage connectors. The SMART-1 can be positioned in any convenient place and does not interfere with shielding or other mounting hardware.

## Remote Preamplifier Option (-HJ)

This option allows all the preamplifier and high voltage connections to be outside a shield and removes the preamplifier and high voltage filter from the "line-of-sight" to the Ge crystal. For low background applications, this option eliminates any possible preamplifier or high voltage filter components that may add to the background inside a shield.

## Carbon Fiber Window Option (-CW)

A carbon fiber window is available for energies greater than about 8 keV. While this window does not pass all the lower energies, carbon fiber has lower Z than Al and does not have any of the hazards associated with Be. See Figures 7 and 8 for transmission data for carbon fiber.

## Low-Background Carbon Fiber Endcap Options (-RB, -LB-C, and -XLB-C)

Carbon Fiber is as strong as Al, Mg, and Cu, creates less background, does not corrode, and can detect energies less than 10 keV.

This lower background material allows for lower Minimum Detectable Activity (MDA) for a specific counting time, which provides another step in increasing sample throughput in low-background counting applications. The lower Z of Carbon Fiber provides a low-energy window without the additional background found in most alloys. See Figures 7 and 8 for transmission characteristics of the Be and carbon fiber windows.

## Low-Background Be/Cu Endcap Options (-RB-B, -LB-B, and -XLB-B)

If the ultimate in low energies is required, a low-background, high purity Be window can be installed in a Cu endcap to minimize the background and still allow energies as low as 3-keV through the front window of the detector.

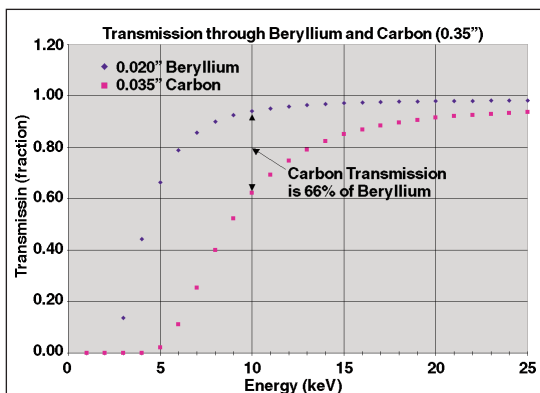

Fig. 7. Transmission through Be and Carbon.



Fig. 5. -HE Detector Option (Carbon Fiber Endcap).

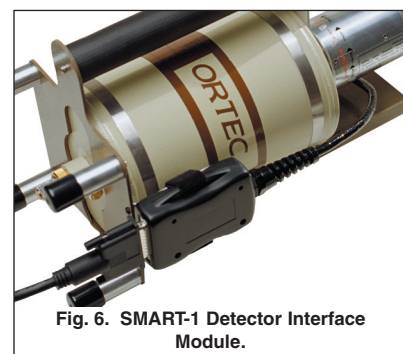

Fig. 6. SMART-1 Detector Interface Module.

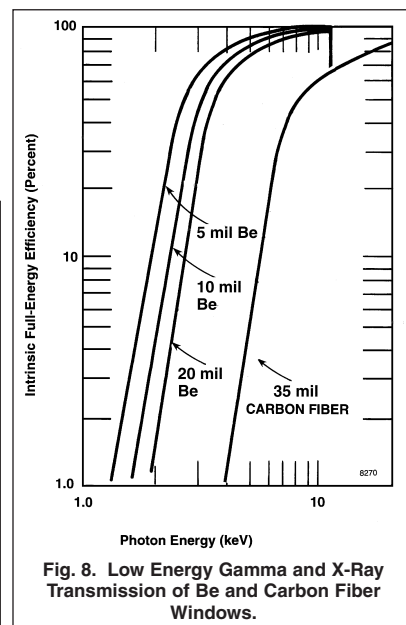

Fig. 8. Low Energy Gamma and X-Ray Transmission of Be and Carbon Fiber Windows.

# GMX Series Coaxial HPGe Detector Product Configuration Guide

## Defining the Detector Model

- See ordering information for option compatibility.

Base Model (example)	PopTop or Streamline	Endcap Diameter	Window Option (if required)	Preamplifier Option (if required)	High Voltage Option (if required)
GMX10	P4 (PopTop) (Streamline)	-70 -76 -83 -95	-RB -RB-B -HE -A -CW -LB-B -LB-C -XLB-B -XLB-C	-PL -HJ	-SMN

# GMX Series Coaxial HPGe Detector Product Configuration Guide

## Streamline Detector Capsule

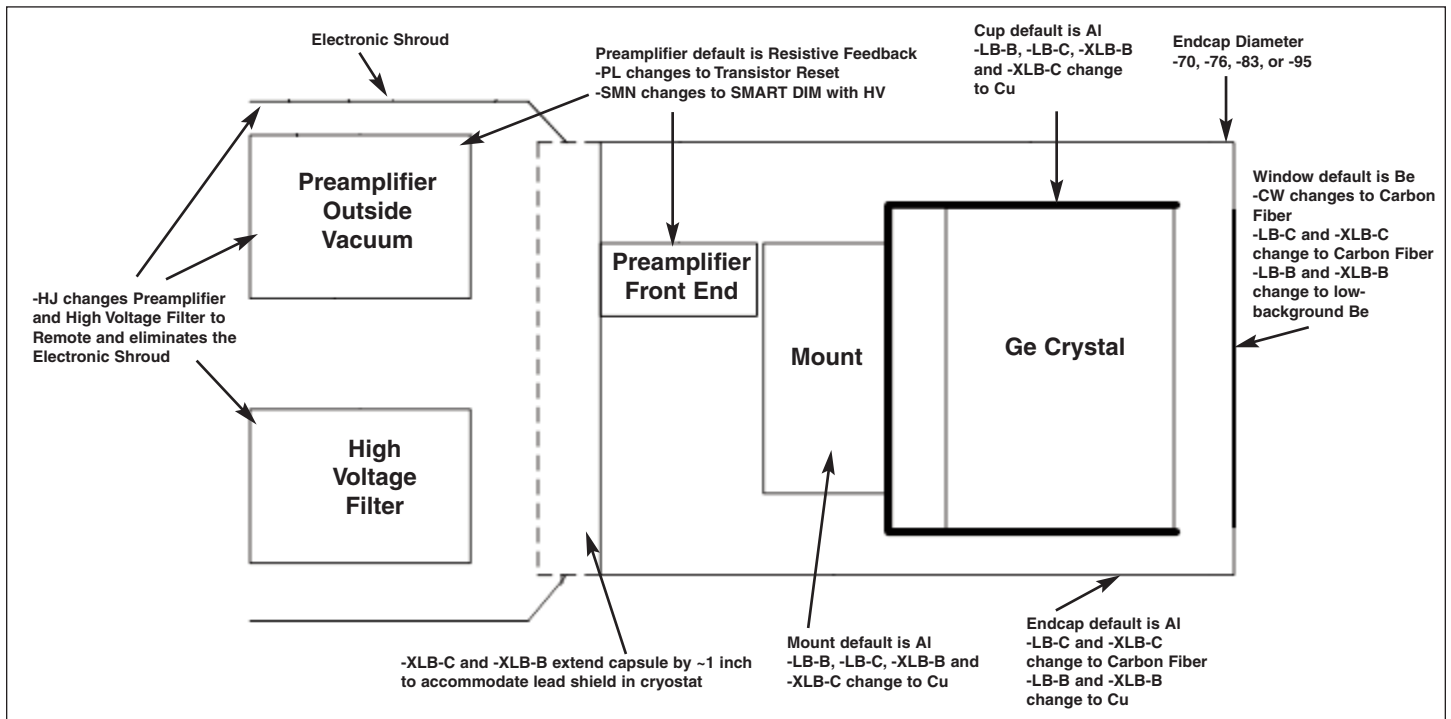

## PopTop Detector Capsule

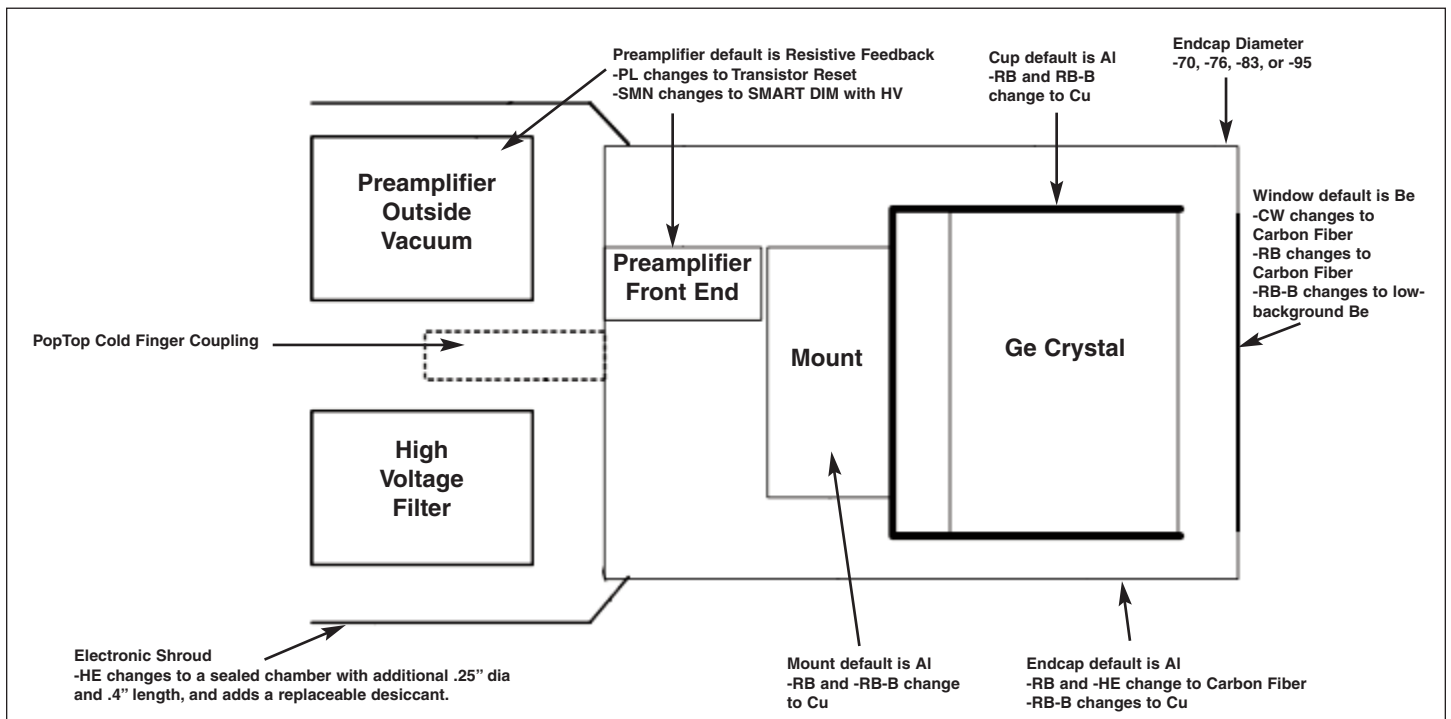

# GMX Series Coaxial HPGe Detector Product Configuration Guide

## Streamline Cryostat and Cryostat/Dewar Assemblies

Streamline systems (detector capsule and cryostat) share the same vacuum, requiring a cryostat or cryostat/dewar selection with the cryostat having a matching diameter to the capsule endcap.

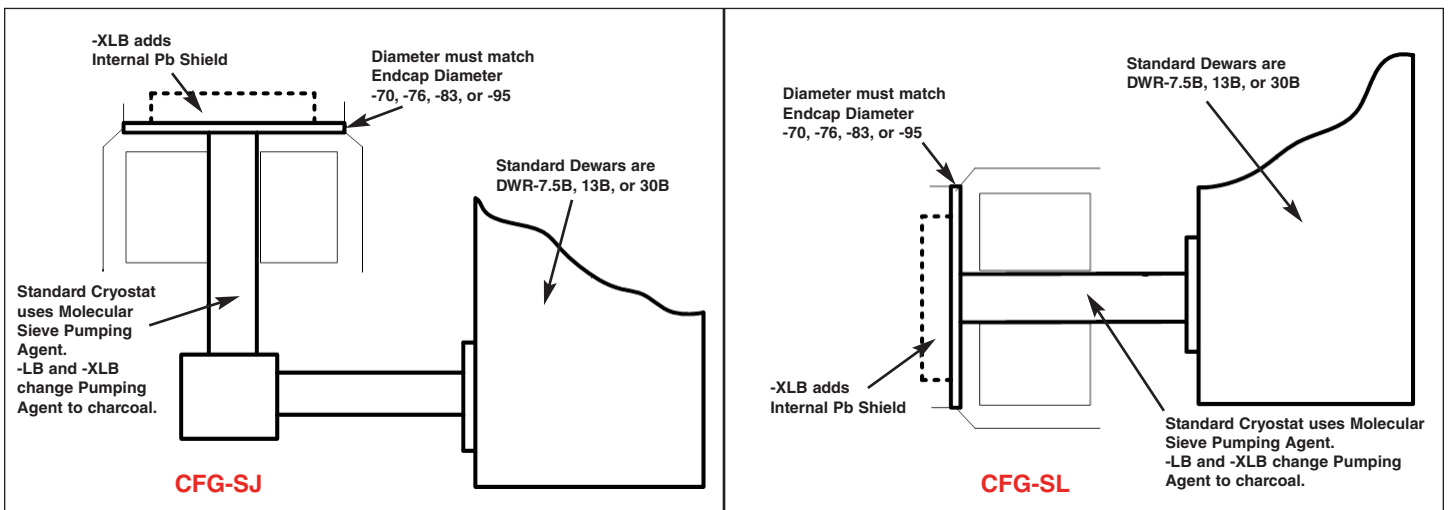
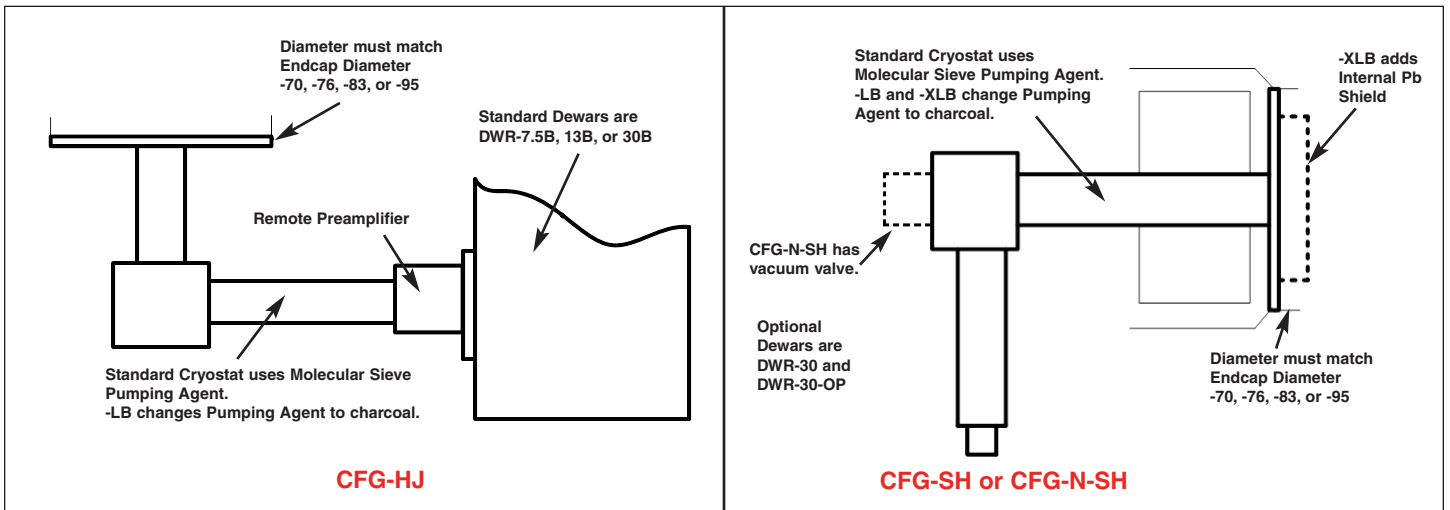
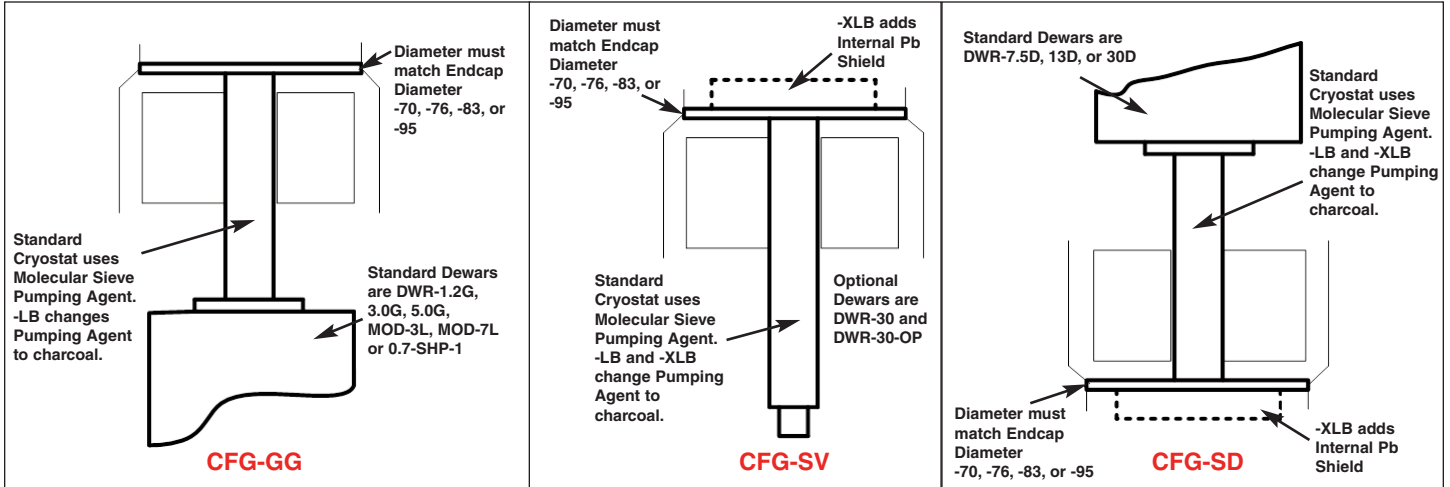

# GMX Series Coaxial HPGe Detector Product Configuration Guide

## PopTop and Streamline Dimensional Data

Streamline systems (detector capsule and cryostat) share the same vacuum, requiring a cryostat or cryostat/dewar selection with the cryostat having a matching diameter to the capsule endcap. A cryostat must be ordered with a Streamline capsule.

The PopTop capsule contains a vacuum unto itself. It can be mounted on any of the available cryostats, cryostat/dewar combinations, or the X-COOLER II mechanical cooling system.

The cryostat and dewar drawings that follow are to be used in conjunction with the accompanying tables of dimensions.

**Note: Cryostat/Dewar drawings are NOT to scale, see tables that follow for complete dimensions.**

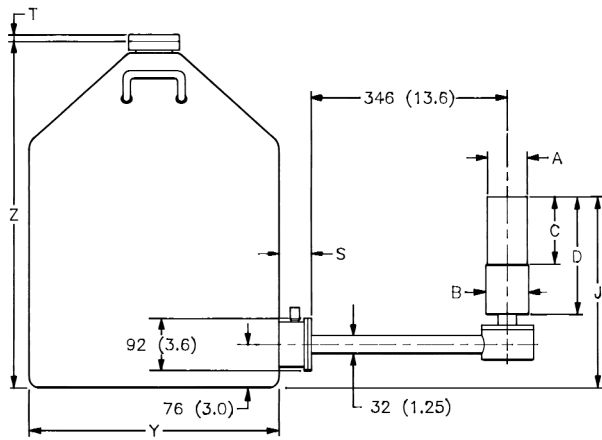

**CFG-SJ, DWR-30B (or -13B or -7.5B)**

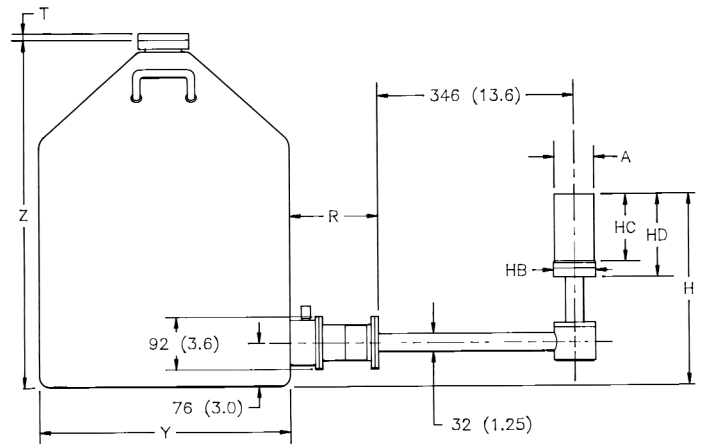

**CFG-HJ, DWR-30B (or -13B or -7.5B)**

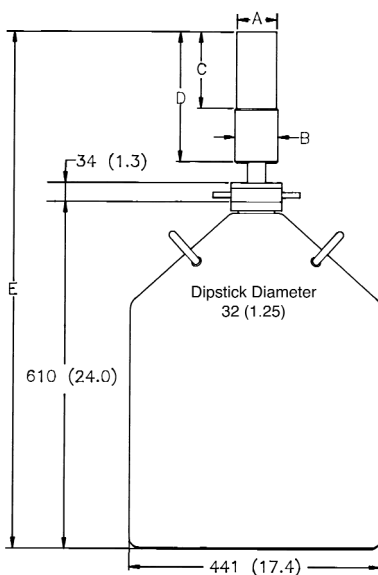

**CFG-SV, DWR-30**

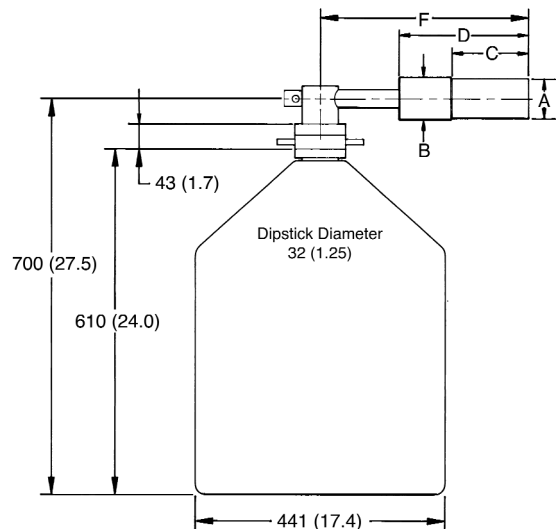

**CFG-N-SH, DWR-30**

# GMX Series Coaxial HPGe Detector Product Configuration Guide

Note: Cryostat/Dewar drawings are NOT to scale, see tables that follow for complete dimensions.

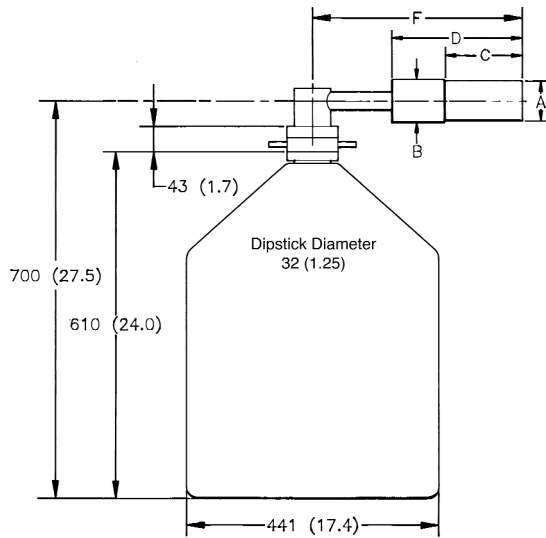

**CFG-SH, DWR-30**

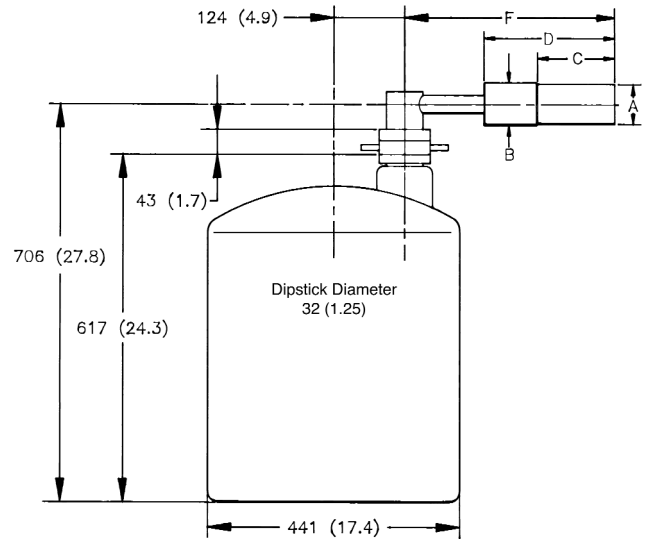

**CFG-SH, DWR-30-OP**

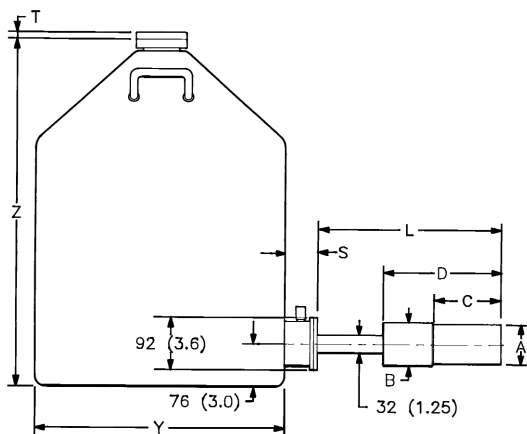

**CFG-PS4-30 (or -13 or -7.5)  
or  
CFG-SL, DWR-30B (or -13B or -7.5B)**

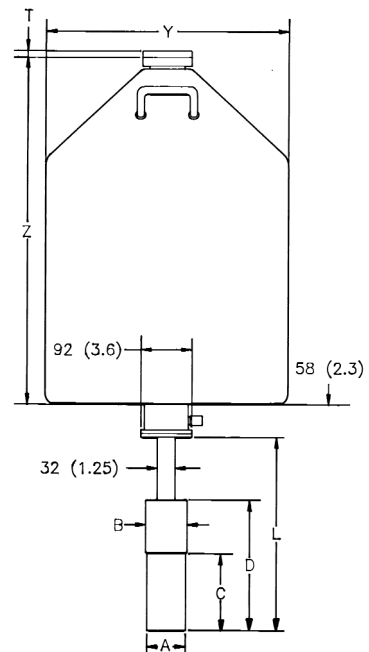

**CFG-PD4-30 (or -13 or -7.5)  
or  
CFG-SD, DWR-30D (or -13D or -7.5D)**

# GMX Series Coaxial HPGe Detector Product Configuration Guide

Note: Cryostat/Dewar drawings are NOT to scale, see tables that follow for complete dimensions.

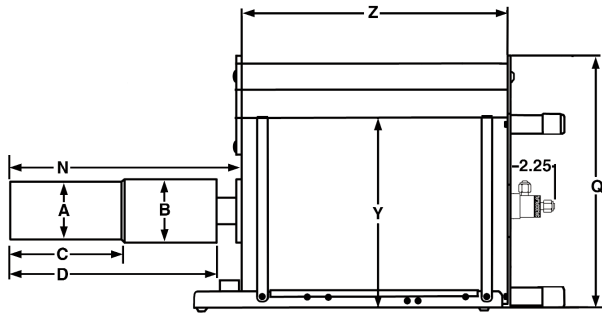

**CFG-PG4-1.2 (or -3 or -5)  
or  
CFG-GG, DWR-1.2G (or -3.0G, -5.0G)**

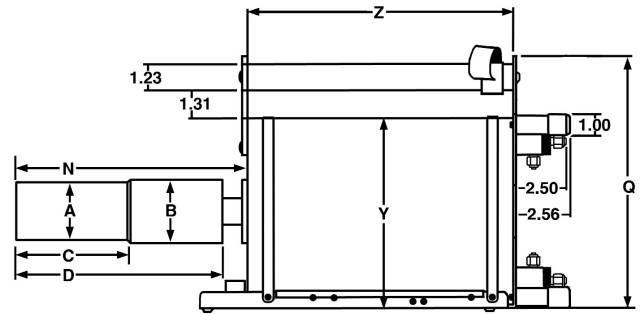

**CFG-PMOD4-3 (or -7)  
or  
CFG-GG, DWR-MOD3L (or -MOD7L)**

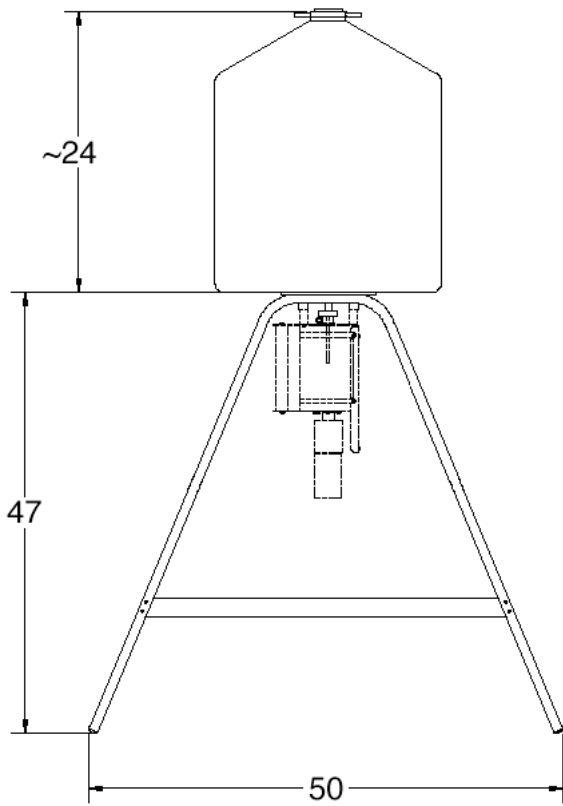

**DWR-S/F**

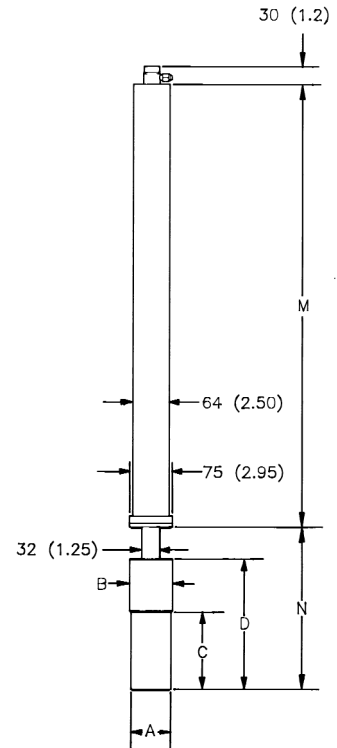

**CFG-PSHP4  
or  
CFG-GG, DWR-0.7-SHP-1**

# GMX Series Coaxial HPGe Detector Product Configuration Guide

Note: Cryostat/Dewar drawings are NOT to scale, see tables that follow for complete dimensions.

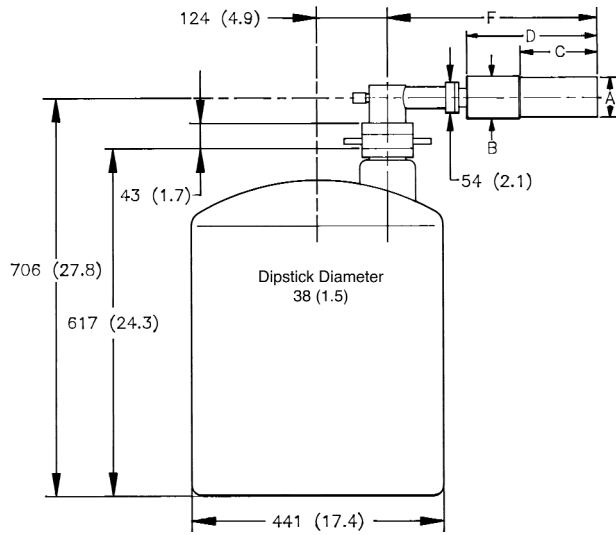

**CFG-PH4, DWR-30-OP**

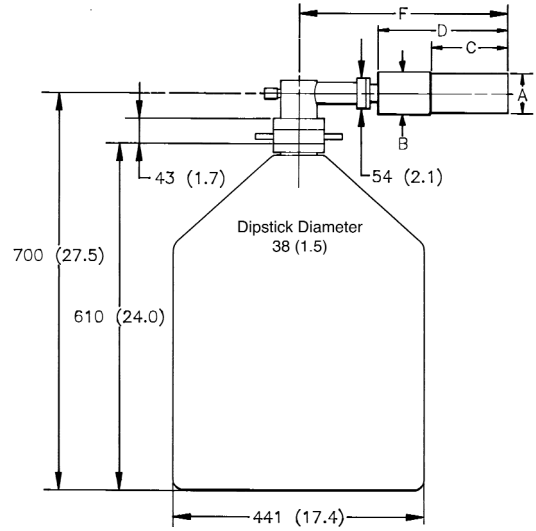

**CFG-PH4, DWR-30**

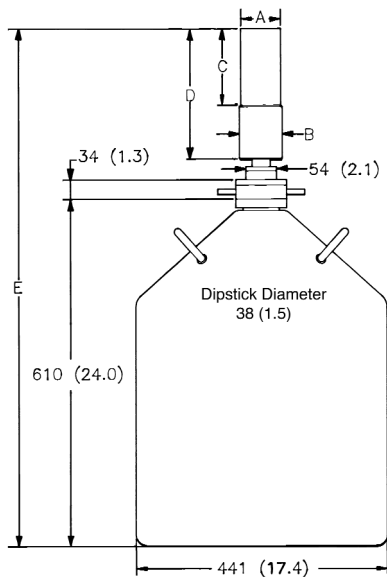

**CFG-PV4, DWR-30**

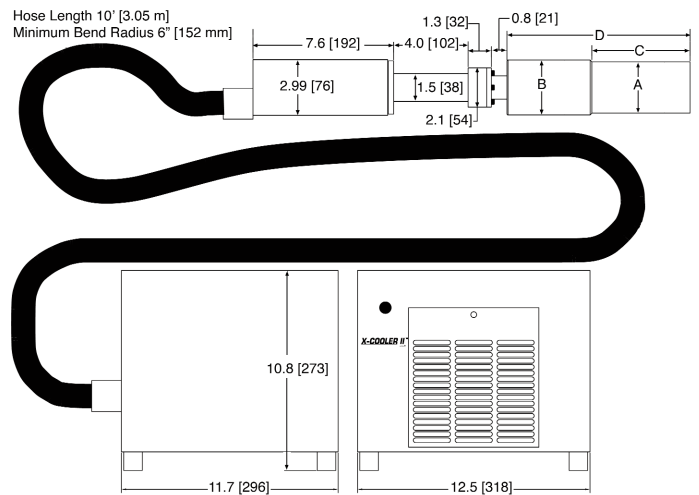

**CFG-X-COOL-II**

# GMX Series Coaxial HPGe Detector

## Product Configuration Guide

### GMX Endcap Diameter and Window

Note that there is an “overlap” of coaxial detector efficiency versus endcap diameter. For example, a 25–35% efficiency detector, depending on diameter, may fit in either a -70, -76 or -83 size endcap. The endcap size must be specified by adding the endcap Model (-xx) to the Detector Model (e.g., GMX25-76 or GMX25P4-70).

If this, or any other dimension is critical, please specify at time of order.

Endcap Model (dia. mm)	-70	-76	-83	-95
Endcap Diameter (in)	2.75	3.00	3.25	3.75
Efficiency	0–35%	25–45%	25–60%	60–100%
Thickness of Al Window	1 mm	1 mm	1 mm	1.5 mm
Thickness of CF Window	.9 mm nominal	.9 mm nominal	.9 mm nominal	.9 mm nominal
Thickness of Be Window	.5 mm	.5 mm	.5 mm	.76 mm

### PopTop GMX Detector Dimensions

- Dimensions are for reference only and subject to change.
- If dimensional constraints are critical, contact the factory.

Endcap Model (dia. mm)			-70	-76	-83	-95
% Efficiencies available in this endcap size			0–35	25–45	25–65	60–110
Dim.	Unit	Tol.				
A	mm (in)	0.3 (0.01)	70 (2.75)	76 (3.0)	83 (3.25)	95 (3.75)
B	mm (in)	0.3 (0.01)	75 (2.95)	88 (3.45)	88 (3.45)	100 (3.95)
C	mm (in)	5 (0.2)	134 (5.3)	165 (6.4)	168 (6.6)	193 (7.6)
D	mm (in)	8 (0.3)	250 (9.8)	282 (11.2)	282 (11.2)	309 (12.2)
E	mm (in)	18 (0.7)	947 (37.3)	982 (38.6)	982 (38.6)	1007 (39.7)
F	mm (in)	10 (0.4)	396 (15.6)	429 (16.9)	429 (16.9)	455 (17.9)
L	mm (in)	10 (0.4)	338 (13.3)	371 (14.6)	371 (14.6)	396 (15.6)
M	mm (in)	8 (0.3)	790 (31.1)	X X	X X	X X
N	mm (in)	10 (0.4)	278 (10.9)	312 (12.3)	312 (12.3)	338 (13.3)

# GMX Series Coaxial HPGe Detector Product Configuration Guide

## Streamline GMX Detector Dimensions

- Dimensions are for reference only and subject to change.
- If dimensional constraints are critical, contact the factory.

			Standard or LB				XLB			
Endcap Model (dia. mm)			-70	-76	-83	-95	-70	-76	-83	-95
% Efficiencies available in this endcap size			0-35	25-45	25-65	60-110	0-35	25-45	25-65	60-110
Dim.	Unit	Tol.								
A	mm (in)	0.3 (0.01)	70 (2.75)	76 (3.0)	83 (3.25)	95 (3.75)	70 (2.75)	76 (3.0)	83 (3.25)	95 (3.75)
B	mm (in)	0.3 (0.01)	75 (2.95)	88 (3.45)	88 (3.45)	100 (3.95)	75 (2.95)	88 (3.45)	88 (3.45)	100 (3.95)
C	mm (in)	5 (0.2)	134 (5.3)	131 (5.1)	134 (5.3)	160 (6.3)	160 (6.3)	157 (6.1)	160 (6.3)	185 (7.3)
D	mm (in)	8 (0.3)	246 (9.7)	259 (10.2)	259 (10.2)	284 (11.2)	272 (10.7)	284 (11.2)	284 (11.2)	310 (12.2)
E	mm (in)	18 (0.7)	916 (36.1)	932 (36.7)	932 (36.7)	957 (37.7)	941 (37.1)	958 (37.7)	958 (37.7)	983 (38.7)
F	mm (in)	10 (0.4)	368 (14.5)	381 (15.0)	381 (15.0)	406 (16.0)	394 (15.5)	406 (16.0)	406 (16.0)	432 (17.0)
H	mm (in)	18 (0.7)	351 (13.8)	364 (14.3)	364 (14.3)	390 (15.3)	X X	X X	X X	X X
HB	mm (in)	0.3 (0.1)	73 (2.9)	85 (3.4)	85 (3.4)	98 (3.9)	X X	X X	X X	X X
HC	mm (in)	5 (0.2)	134 (5.3)	135 (5.3)	135 (5.3)	160 (6.3)	X X	X X	X X	X X
HD	mm (in)	10 (0.4)	162 (6.4)	175 (6.9)	175 (6.9)	200 (7.9)	X X	X X	X X	X X
J	mm (in)	10 (0.4)	380 (15)	393 (15.5)	393 (15.5)	418 (16.5)	405 (16)	418 (16.5)	418 (16.5)	444 (17.5)
L	mm (in)	10 (0.4)	338 (13.3)	351 (13.8)	351 (13.8)	376 (14.8)	363 (14.3)	376 (14.8)	376 (14.8)	401 (15.8)
M	mm (in)	8 (0.3)	516 (20.3)	X X	X X	X X	516 (20.3)	X X	X X	X X
N	mm (in)	10 (0.4)	278 (11)	292 (11.5)	292 (11.5)	318 (12.5)	305 (12)	318 (12.5)	318 (12.5)	243 (13.5)

# GMX Series Coaxial HPGe Detector

## Product Configuration Guide

### Gamma Gage and Side-Looking Dewar Dimensions

• Dimensions are for reference only and subject to change.

• If dimensional constraints are critical, contact the factory.

			Cryostat/Dewar or Dewar Type								
			CFG-PG4 and DWR-x.xG			CFG-PMOD4 and DWR-MOD-xL		CFG-PS4, CFG-PD4, DWR-xxB and DWR-xxD			
			VOLUME			VOLUME		VOLUME			
Dim.	UNIT	TOL. ±	1.2L	3L	5L	3L	7L	7.5L	13L	30L	
Q	mm (in)	13 (0.5)	229 (9.0)	302 (11.9)	302 (11.9)	229 (9.0)	302 (11.9)	X X	X X	X X	
R	mm (in)	10 (0.4)	X X	X X	X X	X X	X X	174 (6.9)	174 (6.9)	155 (16.1)	
S	mm (in)	7.6 (0.3)	X X	X X	X X	X X	X X	77 (3.0)	77 (3.0)	60 (2.3)	
T	mm (in)	5 (0.2)	X X	X X	X X	X X	X X	10 (0.4)	10 (0.4)	13 (0.5)	
Y	mm (in)	5 (0.2)	157 (6.2)	229 (9.0)	229 (9.0)	157 (6.2)	229 (9.0)	224 (8.8)	307 (12.1)	442 (17.4)	
Z	mm (in)	5 (0.2)	229 (9.0)	267 (10.5)	419 (16.5)	292 (11.5)	320 (12.6)	452 (17.8)	429 (16.9)	610 (24.0)	

# GMX Series Coaxial HPGe Detector Product Configuration Guide

## Example Model Numbers

### Streamline Configuration

GMX10-70	10% efficiency GMX detector with 70-mm diameter endcap.
CFG-GG-70	Portable Gamma Gage cryostat with matching 70-mm diameter flange.
DWR-1.2G	1.2 liter all-position dewar for Gamma Gage cryostat.
GMX35-76-A-SMN	35% efficiency GMX detector with 76-mm diameter endcap, Al window, and SMART-1 preamplifier and high voltage supply.
CFG-SD-76	Downlooking cryostat with matching 76-mm diameter flange.
DWR-7.5D	7.5 liter downlooking dewar for downlooking cryostat.
GMX50-83-HJ	50% efficiency GMX detector with 83-mm diameter endcap, remote preamplifier and high voltage filter.
CFG-HJ-83	“J” configuration cryostat with remote fittings for the preamplifier and high voltage filter.
DWR-30B	30 liter side port dewar for “HJ” cryostat.
GMX70-95-LB-C-PL	70% efficiency GMX detector with 95-mm diameter low background carbon fiber endcap, and Plus preamplifier.
CFG-SV-LB-95	Vertical “dipstick” style cryostat with matching 95-mm flange and low background charcoal pumping agent.
DWR-30	30 liter top port dewar that accepts “dipstick” style cryostats.

### PopTop Configuration

GMX10P4-70	10% efficiency GMX detector with 70-mm diameter endcap.
CFG-PG4-1.2	Portable Gamma Gage cryostat with 1.2 liter all-position dewar.
GMX35P4-76-SMN	35% efficiency GMX detector with 76-mm diameter endcap and SMART-1 preamplifier and high voltage supply.
CFG-PD4-7.5	Downlooking cryostat with 7.5 liter dewar.
GMX50-83-HE	50% efficiency GMX detector with 83-mm diameter carbon fiber endcap with sealed preamplifier and high voltage filter.
CFG-PG4-3	Portable Gamma Gage cryostat with 3 liter all-position dewar.
GMX50P4-83-RB-SMN	50% efficiency GMX detector with 83-mm diameter reduced background carbon fiber endcap, and SMART-1 preamplifier and high voltage supply.
CFG-PV4	Vertical “dipstick” style cryostat.
DWR-30	30 liter top port dewar that accepts “dipstick” style cryostats.

# GMX Series Coaxial HPGe Detector

## Product Configuration Guide

### Ordering Information

- For Streamline remove the "P4" from the model number.
- Endcap Diameter must be specified, see Endcap Diameter.
- FWHM = Full Width at Half Maximum; FW.1M = Full Width at One-Tenth Maximum; FW.02M = Full Width at One-Fiftieth Maximum; total system resolution for a source at 1000 counts/s measured in accordance with ANSI/IEEE Std. 325-1996, using ORTEC standard electronics.
- If dimensional considerations are critical, contact factory.
- Cryostat and dewar or other cooling device are not included with detector.
- Cryostat and dewar or other cooling device are required for operation.
- A cryostat must be ordered with a Streamline detector.
- Monte Carlo drawings included.

Model No.	Relative Photopeak Efficiency (%)	Resolution		Peak-to-Compton Ratio	Peak Shape		Endcap Diameter (mm)	Be Window Thickness (mm)
		@ 5.9 keV (eV FWHM)	@1.33 MeV (keV FWHM)		FW.1M/ FWHM	FW.02M/ FWHM typical		
GMX10P4	10	600	1.80	40:1	1.9	2.6	-70	0.51
GMX15P4	15	635	1.85	44:1	1.9	2.6	-70	0.51
GMX20P4	20	650	1.90	48:1	1.9	2.8	-70	0.51
GMX25P4	25	690	1.90	48:1	1.9	2.8	-70, -76, -83	0.51
GMX30P4	30	715	1.90	52:1	1.9	2.8	-70, -76, -83	0.51
GMX35P4	35	730	1.95	55:1	2.0	3.0	-70, -76, -83	0.51
GMX40P4	40	760	2.0	59:1	2.0	3.0	-76, -83	0.51
GMX45P4	45	800	2.1	60:1	2.0	3.0	-76, -83	0.51
GMX50P4	50	800	2.2	58:1	2.0	3.0	-83	0.51
		(keV FWHM)						
GMX60P4	60	1.10	2.3	56:1	2.0	3.0	-83, -95	0.51, 0.76
GMX70P4	70	1.10	2.3	60:1	2.0	3.0	-95	0.76
GMX80P4	80	1.10	2.3	63:1	2.0	3.0	-95	0.76
GMX90P4	90	1.20	2.4	64:1	2.1	3.1	-95	0.76
GMX100P4	100	1.20	2.5	64:1	2.2	3.2	-95	0.76

### GAMMA-X Detector Options

- RB PopTop Only. Reduced background PopTop capsule with Carbon Fiber endcap, add "-RB" to the model number. Not compatible with -HE option.
- RB-B PopTop Only. Reduced background PopTop capsule with Be window in Cu endcap, add "-RB-B" to the model number. Not compatible with -HE option.
- HE PopTop Only. Harsh Environment Option for PopTop detectors 76 mm and larger, add "-HE" to the model number. Not compatible with -RB or -RB-B option. This option deletes the 5.9-keV resolution specification.
- PL PLUS Ultra-high-count-rate Preamplifier, add "-PL" to the model number. Not compatible with -HJ option.
- SMN SMART-1 detector option for negative bias detector, add "-SMN" to the model number. Not compatible with -HJ option.
- A Aluminum endcap (no Be) at no extra charge, add "-A" to the model number. This option deletes the 5.9-keV resolution specification.
- CW Carbon Fiber Window (0.9 mm thick) at no extra charge, add "-CW" to the model number. This option deletes the 5.9-keV resolution specification.
- LB-B Streamline Only. Low-Background Detector with Be window in Cu endcap, add "-LB-B" to the model number. Requires selection of a Low-Background LB cryostat.
- LB-C Streamline Only. Low-Background Detector with Carbon Fiber Endcap, add "-LB-C" to the model number. Requires selection of a Low-Background LB cryostat. This option deletes the 5.9-keV resolution specification.
- XLB-B Streamline Only. Extra-Low-Background Detector with Be window in Cu endcap, add "-XLB-B" to the model number. Requires selection of a Low-Background XLB cryostat. Not compatible with -HJ option.
- XLB-C Streamline Only. Extra-Low-Background Detector with Carbon Fiber Endcap, add "-XLB-C" to the model number. Requires selection of a Low-Background XLB cryostat. This option deletes the 5.9-keV resolution specification. Not compatible with -HJ option.
- HJ Streamline Only. Remote preamplifier and high voltage filter for use with HJ type cryostat, add "-HJ" to the model number. Requires selection of HJ cryostat. Not compatible with -PL, -SMN, -XLB-B, or -XLB-C options.

# GMX Series Coaxial HPGe Detector Product Configuration Guide

## GAMMA-X PopTop Cryostats and Dewars

• Dewar included except where marked \*.

Model No.	Description
CFG-MG4-1.2G	Gamma Gage Cryostat with 1.2-liter Dewar, Pistol Grip handle and mounting holes to fit the M-1-T1 Tripod (for 83 mm or smaller endcaps)
CFG-PD4-7.5	Down-looking Cryostat with 7.5-liter Dewar
CFG-PD4-13	Down-looking Cryostat with 13-liter Dewar
CFG-PD4-30	Down-looking Cryostat with 30-liter Dewar
CFG-PG4-1.2	Gamma Gage Cryostat with 1.2-liter Dewar (for 83 mm or smaller endcaps) (not compatible with -HE option)
CFG-PG4-3	Gamma Gage Cryostat with 3-liter Dewar
CFG-PG4-5	Gamma Gage Cryostat with 5-liter Dewar
CFG-PH4	Horizontal Cryostat (Dipstick type). Includes LNTC1.5WH. Dewar not included.* Choose DWR-30 or DWR-30-OP.
CFG-PMOD4-3	Gamma Gage Cryostat with 3-liter Multi-Orientation Dewar
CFG-PMOD4-7	Gamma Gage Cryostat with 7-liter Multi-Orientation Dewar
CFG-PS4-7.5	Side-Looking Cryostat with 7.5-liter Dewar
CFG-PS4-13	Side-Looking Cryostat with 13-liter Dewar
CFG-PS4-30	Side-Looking Cryostat with 30-liter Dewar
CFG-PSHP4	Down-Looking Shallow-Hole Probe with 0.7-liter Dewar
CFG-PV4	Vertical Cryostat (Dipstick type). Includes LNTC1.5WH. Dewar not included.* Choose DWR-30 or DWR-30-OP.
DWR-30	30-liter Dewar
DWR-30-OP	30-liter Offset-Port Dewar
DWR-S/F	Storage Fill Dewar for CFG-PG4-X
CFG-X-COOL-II-115	X-COOLER II with PopTop connector using 110-120 V ac, 60 Hz Input Power
CFG-X-COOL-II-230	X-COOLER II with PopTop connector using 220-240 V ac, 50 Hz Input Power

# GMX Series Coaxial HPGe Detector

## Product Configuration Guide

### GAMMA-X Streamline Cryostats

- Select dewar from GAMMA-X Streamline Dewars. Dewar included except where marked\*.
- Append matching Detector Endcap Size designation to cryostat model: -70, -76, -83, -95 [e.g., CFG-SJ-95 for GMX70-95 or CFG-SL-XLB-83 for GMX25-83-XLB-B]

Model No.	Description
CFG-GG	Gamma Gage Cryostat Dewar
CFG-HJ	J-type Cryostat with Remote Preamp and Dewar. (for -HJ option only)
CFG-SD	Down-Looking Cryostat with Dewar
CFG-SH	Horizontal Cryostat (Dipstick type). Includes LNTC1.25WH. Dewar not included.*
CFG-N-SH	Horizontal Cryostat with vacuum valve (Dipstick type). Includes LNTC1.25WH. Dewar not included.* Requires model VV02 and model 496-1 (110 V/60 Hz) or model 496-2 (220 V/50 Hz).
CFG-SJ	J-type Cryostat with Dewar
CFG-SL	Side-Looking Cryostat with Dewar
CFG-SV	Vertical Cryostat with (Dipstick type). Includes LNTC1.25WH. Dewar not included.*

### LOW-BACKGROUND

CFG-GG-LB	Low-Background Gamma Gage Cryostat with Dewar
CFG-HJ-LB	Low-Background J-type Cryostat with Remote Preamp and Dewar. (for -HJ option only)
CFG-SD-LB	Low-Background Down-Looking Cryostat with Dewar
CFG-SH-LB	Low-Background Horizontal Cryostat (Dipstick type). Includes LNTC1.25WH. Dewar not included.*
CFG-SJ-LB	Low-Background J-type Cryostat with Dewar
CFG-SL-LB	Low-Background Side-Looking Cryostat with Dewar
CFG-SV-LB	Low-Background Vertical Cryostat (Dipstick type). Includes LNTC1.25WH. Dewar not included.*
CFG-SD-XLB	Extra-Low-Background Down-Looking Cryostat with Dewar
CFG-SH-XLB	Extra-Low-Background Horizontal Cryostat (Dipstick type). Includes LNTC1.25WH. Dewar not included.*
CFG-SJ-XLB	Extra-Low-Background J-type Cryostat with Dewar
CFG-SL-XLB	Extra-Low-Background Side-Looking Cryostat with Dewar
CFG-SV-XLB	Extra-Low-Background Vertical Cryostat (Dipstick type). Includes LNTC1.25WH. Dewar not included.*

### GAMMA-X Streamline Dewars

For Cryostat	Choose	Description	
CFG-GG	DWR-1.2G	1.2-liter All-Orientation Dewar	Included with Cryostat
	DWR-3.0G	3.0-liter All-Orientation Dewar	Included with Cryostat
	DWR-5.0G	5.0-liter All-Orientation Dewar	Included with Cryostat
	DWR-MOD-3L	3-liter Multi-Orientation Dewar	Included with Cryostat
	DWR-MOD-7L	7-liter Multi-Orientation Dewar	Included with Cryostat
	DWR-0.7-SHP-1	0.7-liter Shallow-Hole Probe Dewar	Included with Cryostat
	DWR-S/F	Storage/Fill Dewar for DWR-XG	
CFG-HJ, SJ, SL	DWR-7.5B	7.5-liter Side-Looking Dewar	Included with Cryostat
	DWR-13B	13-liter Side-Looking Dewar	Included with Cryostat
	DWR-30B	30-liter Side-Looking Dewar	Included with Cryostat
CFG-SD	DWR-7.5D	7.5-liter Down-Looking Dewar	Included with Cryostat
	DWR-13D	13-liter Down-Looking Dewar	Included with Cryostat
	DWR-30D	30-liter Down-Looking Dewar	Included with Cryostat
CFG-SV, SH, N-SH	DWR-30-OP	30-liter Offset-Port Dewar	
	DWR-30	30-liter Dewar	

GMX Series Coaxial HPGe Detector  
Product Configuration Guide

---

# GMX Series Coaxial HPGe Detector Product Configuration Guide

---

Specifications subject to change  
072611

**ORTEC**<sup>®</sup>

**[www.ortec-online.com](http://www.ortec-online.com)**

Tel. (865) 482-4411 • Fax (865) 483-0396 • [ortec.info@ametek.com](mailto:ortec.info@ametek.com)  
801 South Illinois Ave., Oak Ridge, TN 37831-0895 U.S.A.  
For International Office Locations, Visit Our Website

**AMETEK**<sup>®</sup>  
ADVANCED MEASUREMENT TECHNOLOGY